

WIRING AND TUBE CLAMPS – MEDIUM DUTY Closed Type – Fur

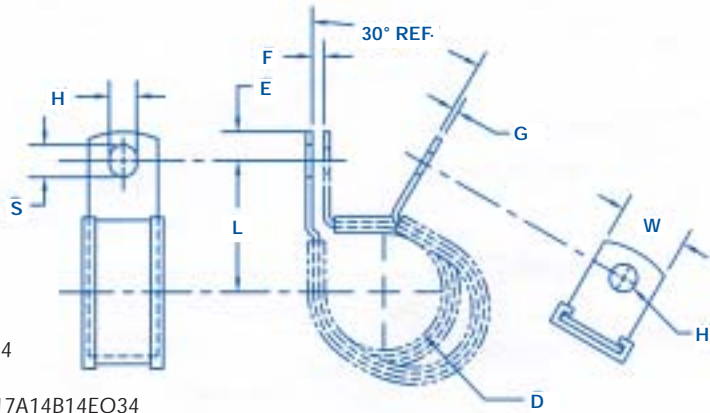

MATERIAL: HD Galv Steel, Chem-Treated G90,
Per ASTM A653/A653M
Type 304 Annealed Stainless Steel,
Per ASTM A240/A666

CUSHION: EPDM per SAE J200/ASTM D2000 BC715A14C12EO34

OPTIONAL CUSHION: Neoprene per AMS3209 SAE J200/ASTM D2000 BC717A14B14EO34
Silicone per AMS3303 SAE J200/ASTMD2000 M2GE506

Clamping Diameter	D	Part Number		H Hole Diameter	L Center To Center	W Width	E Hole Center To End	F Gap	S Slot Length	Gage	
		HD Galv Part Number	Stainless Part Number							HD Galv Gage	Stainless Gage
		±.031	±.005							±.031	±.010
.187		COL0307Z1	COL0307SS	.203	.916	.500	.250	.062	.297	.032	.032
		COL0309Z1	COL0309SS	.281	.854	.500	.312	.062	.375	.032	.032
		COL0311Z1	COL0311SS	.343	.791	.625	.375	.062	.437	.032	.032
		COL0313Z1	COL0313SS	.406	.729	.750	.437	.062	.500	.032	.032
.250		COL0407Z1	COL0407SS	.203	.711	.500	.250	.062	.297	.032	.032
		COL0409Z1	COL0409SS	.281	.674	.500	.312	.062	.375	.032	.032
		COL0411Z1	COL0411SS	.343	.611	.625	.375	.062	.437	.032	.032
		COL0413Z1	COL0413SS	.406	.656	.750	.437	.062	.500	.032	.032
		COL0415Z1	COL0415SS	.468	.718	.750	.500	.062	.562	.032	.032
		COL0417Z1	COL0417SS	.531	.781	1.000	.562	.062	.625	.032	.032
.312		COL0507Z1	COL0507SS	.203	.569	.500	.250	.062	.297	.032	.032
		COL0509Z1	COL0509SS	.281	.562	.500	.312	.062	.375	.032	.032
		COL0511Z1	COL0511SS	.343	.625	.625	.375	.062	.437	.032	.032
		COL0513Z1	COL0513SS	.406	.687	.750	.437	.062	.500	.032	.032
		COL0515Z1	COL0515SS	.468	.750	.750	.500	.062	.562	.032	.032
		COL0517Z1	COL0517SS	.531	.812	1.000	.562	.062	.625	.032	.032
.375		COL0607Z1	COL0607SS	.203	.500	.500	.250	.062	.297	.032	.032
		COL0609Z1	COL0609SS	.281	.593	.500	.312	.062	.375	.032	.032
		COL0611Z1	COL0611SS	.343	.656	.625	.375	.062	.437	.032	.032
		COL0613Z1	COL0613SS	.406	.718	.750	.437	.062	.500	.032	.032
		COL0615Z1	COL0615SS	.468	.781	.750	.500	.062	.562	.032	.032
		COL0617Z1	COL0617SS	.531	.843	1.000	.562	.062	.625	.032	.032
.437		COL0707Z1	COL0707SS	.203	.531	.500	.250	.062	.297	.032	.032
		COL0709Z1	COL0709SS	.281	.625	.500	.312	.062	.375	.032	.032
		COL0711Z1	COL0711SS	.343	.687	.625	.375	.062	.437	.048	.032
		COL0713Z1	COL0713SS	.406	.750	.750	.437	.062	.500	.048	.032
		COL0715Z1	COL0715SS	.468	.812	.750	.500	.062	.562	.048	.032
		COL0717Z1	COL0717SS	.531	.875	1.000	.562	.062	.625	.048	.032
.500		COL0807Z1	COL0807SS	.203	.562	.500	.250	.062	.297	.032	.032
		COL0809Z1	COL0809SS	.281	.656	.500	.312	.062	.375	.032	.032
		COL0811Z1	COL0811SS	.343	.718	.625	.375	.062	.437	.048	.032
		COL0813Z1	COL0813SS	.406	.781	.750	.437	.062	.500	.048	.032
		COL0815Z1	COL0815SS	.468	.843	.750	.500	.062	.562	.048	.032
		COL0817Z1	COL0817SS	.531	.906	1.000	.562	.062	.625	.048	.032

Additional clamping diameters and configurations are available.

WIRING AND TUBE CLAMPS – MEDIUM DUTY Closed Type – Furnished Open – Extr

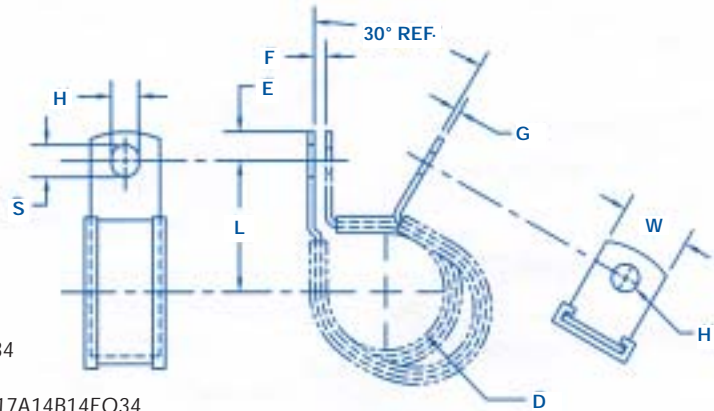

MATERIAL: HD Galv Steel, Chem-Treated G90,
Per ASTM A653/A653M
Type 304 Annealed Stainless Steel,
Per ASTM A240/A666

CUSHION: EPDM per SAE J200/ASTM D2000 BC715A14C12EO34

OPTIONAL CUSHION: Neoprene per AMS3209 SAE J200/ASTM D2000 BC717A14B14EO34
Silicone per AMS3303 SAE J200/ASTMD2000 M2GE506

D	Part Number		H	L	W	E	F	S	Gage	
	HD Galv Part Number	Stainless Part Number							HD Galv Gage	Stainless Gage
Clamping Diameter			Hole Diameter	Center To Center	Width	Hole Center To End	Gap	Slot Length		
±.031			±.005	±.031	±.010	±.015	±.031	±.020	±.002	±.002
.562	COL0907Z1	COL0907SS	.203	.687	.500	.250	.062	.297	.032	.032
	COL0909Z1	COL0909SS	.281	.750	.500	.312	.062	.375	.032	.032
	COL0911Z1	COL0911SS	.343	.812	.625	.375	.062	.437	.048	.032
	COL0913Z1	COL0913SS	.406	.875	.750	.437	.062	.500	.048	.032
	COL0915Z1	COL0915SS	.468	.937	.750	.500	.062	.562	.048	.032
	COL0917Z1	COL0917SS	.531	1.000	1.000	.562	.062	.625	.048	.032
.625	COL1007Z1	COL1007SS	.203	.718	.500	.250	.062	.297	.032	.032
	COL1009Z1	COL1009SS	.281	.781	.500	.312	.062	.375	.032	.032
	COL1011Z1	COL1011SS	.343	.843	.625	.375	.062	.437	.048	.032
	COL1013Z1	COL1013SS	.406	.906	.750	.437	.062	.500	.048	.032
	COL1015Z1	COL1015SS	.468	.968	.750	.500	.062	.562	.048	.032
	COL1017Z1	COL1017SS	.531	1.031	1.000	.562	.062	.625	.048	.032
.687	COL1107Z1	COL1107SS	.203	.750	.500	.250	.062	.297	.032	.032
	COL1109Z1	COL1109SS	.281	.812	.500	.312	.062	.375	.032	.032
	COL1111Z1	COL1111SS	.343	.875	.625	.375	.062	.437	.048	.032
	COL1113Z1	COL1113SS	.406	.937	.750	.437	.062	.500	.048	.032
	COL1115Z1	COL1115SS	.468	1.000	.750	.500	.062	.562	.048	.032
	COL1117Z1	COL1117SS	.531	1.062	1.000	.562	.062	.625	.048	.032
.750	COL1207Z1	COL1207SS	.203	.781	.500	.250	.062	.297	.032	.032
	COL1209Z1	COL1209SS	.281	.843	.500	.312	.062	.375	.032	.032
	COL1211Z1	COL1211SS	.343	.906	.625	.375	.062	.437	.048	.032
	COL1213Z1	COL1213SS	.406	.968	.750	.437	.062	.500	.048	.032
	COL1215Z1	COL1215SS	.468	1.031	.750	.500	.062	.562	.048	.032
	COL1217Z1	COL1217SS	.531	1.095	1.000	.562	.062	.625	.048	.032
.812	COL1307Z1	COL1307SS	.203	.812	.500	.250	.062	.297	.032	.032
	COL1309Z1	COL1309SS	.281	.875	.500	.312	.062	.375	.032	.032
	COL1311Z1	COL1311SS	.343	.937	.625	.375	.062	.437	.048	.032
	COL1313Z1	COL1313SS	.406	1.000	.750	.437	.062	.500	.048	.032
	COL1315Z1	COL1315SS	.468	1.062	.750	.500	.062	.562	.048	.032
	COL1317Z1	COL1317SS	.531	1.125	1.000	.562	.062	.625	.048	.032

Additional clamping diameters and configurations are available.

WIRING AND TUBE CLAMPS – MEDIUM DUTY Closed Type – Fur



COL

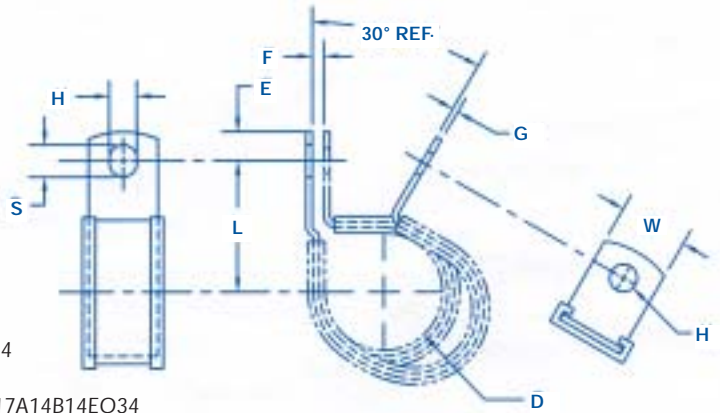

MATERIAL: HD Galv Steel, Chem-Treated G90,
Per ASTM A653/A653M
Type 304 Annealed Stainless Steel,
Per ASTM A240/A666

CUSHION: EPDM per SAE J200/ASTM D2000 BC715A14C12EO34

OPTIONAL CUSHION: Neoprene per AMS3209 SAE J200/ASTM D2000 BC717A14B14EO34
Silicone per AMS3303 SAE J200/ASTMD2000 M2GE506

D Clamping Diameter ±.031	Part Number		H Hole Diameter ±.005	L Center To Center ±.031	W Width ±.010	E Hole Center To End ±.015	F Gap ±.031	S Slot Length ±.020	Gage	
	HD Galv Part Number	Stainless Part Number							HD Galv Gage	Stainless Gage
									±.002	±.002
.875	COL1407Z1	COL1407SS	.203	.843	.500	.250	.062	.297	.032	.032
	COL1409Z1	COL1409SS	.281	.906	.500	.312	.062	.375	.032	.032
	COL1411Z1	COL1411SS	.343	.968	.625	.375	.062	.437	.048	.032
	COL1413Z1	COL1413SS	.406	1.031	.750	.437	.062	.500	.048	.032
	COL1415Z1	COL1415SS	.468	1.093	.750	.500	.062	.562	.048	.032
	COL1417Z1	COL1417SS	.531	1.156	1.000	.562	.062	.625	.048	.032
.937	COL1507Z1	COL1507SS	.203	.875	.500	.250	.062	.297	.032	.032
	COL1509Z1	COL1509SS	.281	.937	.500	.312	.062	.375	.032	.032
	COL1511Z1	COL1511SS	.343	1.000	.625	.375	.062	.437	.048	.032
	COL1513Z1	COL1513SS	.406	1.062	.750	.437	.062	.500	.048	.032
	COL1515Z1	COL1515SS	.468	1.125	.750	.500	.062	.562	.048	.032
	COL1517Z1	COL1517SS	.531	1.187	1.000	.562	.062	.625	.048	.032
1.000	COL1607Z1	COL1607SS	.203	.906	.500	.250	.062	.297	.032	.032
	COL1609Z1	COL1609SS	.281	.968	.500	.312	.062	.375	.032	.032
	COL1611Z1	COL1611SS	.343	1.031	.625	.375	.062	.437	.048	.032
	COL1613Z1	COL1613SS	.406	1.093	.750	.437	.062	.500	.048	.032
	COL1615Z1	COL1615SS	.468	1.156	.750	.500	.062	.562	.048	.032
	COL1617Z1	COL1617SS	.531	1.218	1.000	.562	.062	.625	.048	.032
1.062	COL1709Z1	COL1709SS	.281	1.000	.500	.312	.062	.375	.048	.048
	COL1711Z1	COL1711SS	.343	1.062	.625	.375	.062	.437	.048	.048
	COL1713Z1	COL1713SS	.406	1.125	.750	.437	.062	.500	.048	.048
	COL1715Z1	COL1715SS	.468	1.187	.750	.500	.062	.562	.048	.048
	COL1717Z1	COL1717SS	.531	1.250	1.000	.562	.062	.625	.048	.048
1.125	COL1809Z1	COL1809SS	.281	1.031	.500	.312	.062	.375	.048	.048
	COL1811Z1	COL1811SS	.343	1.093	.625	.375	.062	.437	.048	.048
	COL1813Z1	COL1813SS	.406	1.156	.750	.437	.062	.500	.048	.048
	COL1815Z1	COL1815SS	.468	1.218	.750	.500	.062	.562	.048	.048
	COL1817Z1	COL1817SS	.531	1.281	1.000	.562	.062	.625	.048	.048

Additional clamping diameters and configurations are available.

WIRING AND TUBE CLAMPS – MEDIUM DUTY Closed Type – Furnished Open – Extr

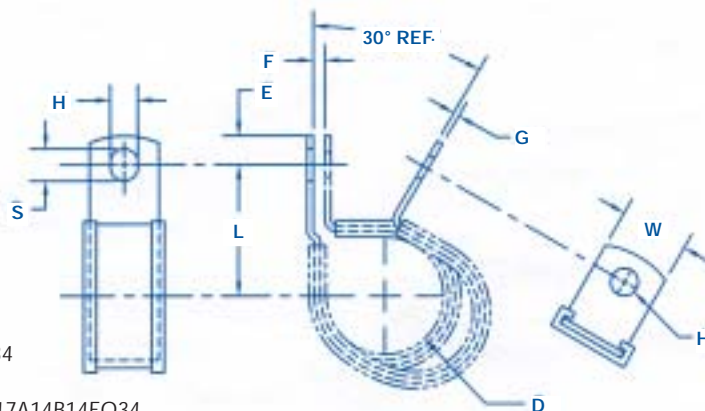

MATERIAL: HD Galv Steel, Chem-Treated G90,
Per ASTM A653/A653M

Type 304 Annealed Stainless Steel,
Per ASTM A240/A666

CUSHION: EPDM per SAE J200/ASTM D2000 BC715A14C12EO34

OPTIONAL

CUSHION: Neoprene per AMS3209 SAE J200/ASTM D2000 BC717A14B14EO34
Silicone per AMS3303 SAE J200/ASTMD2000 M2GE506

D	Part Number		H	L	W	E	F	S	Gage	
	HD Galv Part Number	Stainless Part Number							HD Galv Gage	Stainless Gage
Clamping Diameter			Hole Diameter	Center To Center	Width	Hole Center To End	Gap	Slot Length		
±.031			±.005	±.031	±.010	±.015	±.031	±.020	±.002	±.002
1.187	COL1909Z1	COL1909SS	.281	1.062	.500	.312	.062	.375	.048	.048
	COL1911Z1	COL1911SS	.343	1.125	.625	.375	.062	.437	.048	.048
	COL1913Z1	COL1913SS	.406	1.187	.750	.437	.062	.500	.048	.048
	COL1915Z1	COL1915SS	.468	1.250	.750	.500	.062	.562	.048	.048
	COL1917Z1	COL1917SS	.531	1.312	1.000	.562	.062	.625	.048	.048
1.250	COL2009Z1	COL2009SS	.281	1.093	.500	.312	.062	.375	.048	.048
	COL2011Z1	COL2011SS	.343	1.156	.625	.375	.062	.437	.048	.048
	COL2013Z1	COL2013SS	.406	1.218	.750	.437	.062	.500	.048	.048
	COL2015Z1	COL2015SS	.468	1.281	.750	.500	.062	.562	.048	.048
	COL2017Z1	COL2017SS	.531	1.343	1.000	.562	.062	.625	.048	.048
1.312	COL2109Z1	COL2109SS	.281	1.125	.500	.312	.062	.375	.048	.048
	COL2111Z1	COL2111SS	.343	1.187	.625	.375	.062	.437	.048	.048
	COL2113Z1	COL2113SS	.406	1.250	.750	.437	.062	.500	.048	.048
	COL2115Z1	COL2115SS	.468	1.312	.750	.500	.062	.562	.048	.048
	COL2117Z1	COL2117SS	.531	1.375	1.000	.562	.062	.625	.048	.048
1.375	COL2209Z1	COL2209SS	.281	1.156	.500	.312	.062	.375	.048	.048
	COL2211Z1	COL2211SS	.343	1.218	.625	.375	.062	.437	.048	.048
	COL2213Z1	COL2213SS	.406	1.281	.750	.437	.062	.500	.048	.048
	COL2215Z1	COL2215SS	.468	1.343	.750	.500	.062	.562	.048	.048
	COL2217Z1	COL2217SS	.531	1.406	1.000	.562	.062	.625	.048	.048
1.437	COL2309Z1	COL2309SS	.281	1.187	.500	.312	.062	.375	.048	.048
	COL2311Z1	COL2311SS	.343	1.250	.625	.375	.062	.437	.048	.048
	COL2313Z1	COL2313SS	.406	1.312	.750	.437	.062	.500	.048	.048
	COL2315Z1	COL2315SS	.468	1.375	.750	.500	.062	.562	.048	.048
	COL2317Z1	COL2317SS	.531	1.437	1.000	.562	.062	.625	.048	.048
1.500	COL2409Z1	COL2409SS	.281	1.218	.500	.312	.062	.375	.048	.048
	COL2411Z1	COL2411SS	.343	1.281	.625	.375	.062	.437	.048	.048
	COL2413Z1	COL2413SS	.406	1.343	.750	.437	.062	.500	.048	.048
	COL2415Z1	COL2415SS	.468	1.406	.750	.500	.062	.562	.048	.048
	COL2417Z1	COL2417SS	.531	1.468	1.000	.562	.062	.625	.048	.048

Additional clamping diameters and configurations are available.

WIRING AND TUBE CLAMPS – MEDIUM DUTY Closed Type – Fur

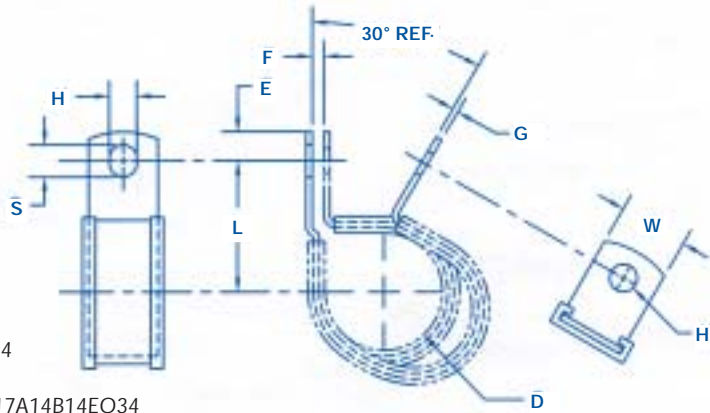

MATERIAL: HD Galv Steel, Chem-Treated G90,
Per ASTM A653/A653M
Type 304 Annealed Stainless Steel,
Per ASTM A240/A666

CUSHION: EPDM per SAE J200/ASTM D2000 BC715A14C12EO34

OPTIONAL CUSHION: Neoprene per AMS3209 SAE J200/ASTM D2000 BC717A14B14EO34
Silicone per AMS3303 SAE J200/ASTMD2000 M2GE506

D Clamping Diameter	Part Number		H Hole Diameter	L Center To Center	W Width	E Hole Center To End	F Gap	S Slot Length	Gage	
	HD Galv Part Number	Stainless Part Number							HD Galv Gage	Stainless Gage
									±.005	±.031
1.562	COL2509Z1	COL2509SS	.281	1.250	.500	.312	.062	.375	.048	.048
	COL2511Z1	COL2511SS	.343	1.312	.625	.375	.062	.437	.048	.048
	COL2513Z1	COL2513SS	.406	1.375	.750	.437	.062	.500	.048	.048
	COL2515Z1	COL2515SS	.468	1.437	.750	.500	.062	.562	.048	.048
	COL2517Z1	COL2517SS	.531	1.500	1.000	.562	.062	.625	.048	.048
1.625	COL2609Z1	COL2609SS	.281	1.281	.500	.312	.062	.375	.048	.048
	COL2611Z1	COL2611SS	.343	1.343	.625	.375	.062	.437	.048	.048
	COL2613Z1	COL2613SS	.406	1.406	.750	.437	.062	.500	.048	.048
	COL2615Z1	COL2615SS	.468	1.468	.750	.500	.062	.562	.048	.048
	COL2617Z1	COL2617SS	.531	1.531	1.000	.562	.062	.625	.048	.048
1.687	COL2709Z1	COL2709SS	.281	1.312	.500	.312	.062	.375	.048	.048
	COL2711Z1	COL2711SS	.343	1.375	.625	.375	.062	.437	.048	.048
	COL2713Z1	COL2713SS	.406	1.437	.750	.437	.062	.500	.048	.048
	COL2715Z1	COL2715SS	.468	1.500	.750	.500	.062	.562	.048	.048
	COL2717Z1	COL2717SS	.531	1.562	1.000	.562	.062	.625	.048	.048
1.750	COL2809Z1	COL2809SS	.281	1.343	.500	.312	.062	.375	.048	.048
	COL2811Z1	COL2811SS	.343	1.406	.625	.375	.062	.437	.048	.048
	COL2813Z1	COL2813SS	.406	1.468	.750	.437	.062	.500	.048	.048
	COL2815Z1	COL2815SS	.468	1.531	.750	.500	.062	.562	.048	.048
	COL2817Z1	COL2817SS	.531	1.593	1.000	.562	.062	.625	.048	.048
1.812	COL2909Z1	COL2909SS	.281	1.375	.500	.312	.062	.375	.048	.048
	COL2911Z1	COL2911SS	.343	1.437	.625	.375	.062	.437	.048	.048
	COL2913Z1	COL2913SS	.406	1.500	.750	.437	.062	.500	.048	.048
	COL2915Z1	COL2915SS	.468	1.562	.750	.500	.062	.562	.048	.048
	COL2917Z1	COL2917SS	.531	1.624	1.000	.562	.062	.625	.048	.048
1.875	COL3009Z1	COL3009SS	.281	1.406	.500	.312	.062	.375	.048	.048
	COL3011Z1	COL3011SS	.343	1.468	.625	.375	.062	.437	.048	.048
	COL3013Z1	COL3013SS	.406	1.531	.750	.437	.062	.500	.048	.048
	COL3015Z1	COL3015SS	.468	1.593	.750	.500	.062	.562	.048	.048
	COL3017Z1	COL3017SS	.531	1.656	1.000	.562	.062	.625	.048	.048

Additional clamping diameters and configurations are available.

WIRING AND TUBE CLAMPS – MEDIUM DUTY Closed Type – Furnished Open – Extr

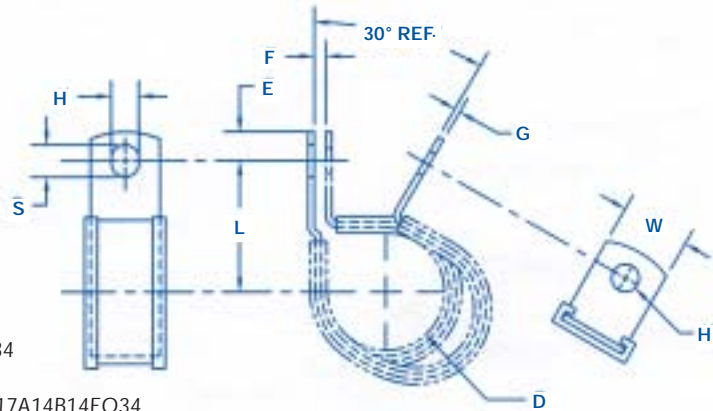

MATERIAL: HD Galv Steel, Chem-Treated G90,
Per ASTM A653/A653M
Type 304 Annealed Stainless Steel,
Per ASTM A240/A666

CUSHION: EPDM per SAE J200/ASTM D2000 BC715A14C12EO34

OPTIONAL CUSHION: Neoprene per AMS3209 SAE J200/ASTM D2000 BC717A14B14EO34
Silicone per AMS3303 SAE J200/ASTMD2000 M2GE506

D Clamping Diameter	Part Number		H	L	W	E	F	S	Gage	
	HD Galv Part Number	Stainless Part Number	Hole Diameter	Center To Center	Width	Hole Center To End	Gap	Slot Length	HD Galv Gage	Stainless Gage
±.031			±.005	±.031	±.010	±.015	±.031	±.020	±.002	±.002
1.937	COL3109Z1	COL3109SS	.281	1.437	.500	.312	.062	.375	.048	.048
	COL3111Z1	COL3111SS	.343	1.500	.625	.375	.062	.437	.048	.048
	COL3113Z1	COL3113SS	.406	1.562	.750	.437	.062	.500	.048	.048
	COL3115Z1	COL3115SS	.468	1.625	.750	.500	.062	.562	.048	.048
	COL3117Z1	COL3117SS	.531	1.687	1.000	.562	.062	.625	.048	.048
2.000	COL3209Z1	COL3209SS	.281	1.500	.500	.312	.062	.375	.048	.048
	COL3211Z1	COL3211SS	.343	1.562	.625	.375	.062	.437	.048	.048
	COL3213Z1	COL3213SS	.406	1.625	.750	.437	.062	.500	.048	.048
	COL3215Z1	COL3215SS	.468	1.687	.750	.500	.062	.562	.048	.048
	COL3217Z1	COL32017SS	.531	1.750	1.000	.562	.062	.625	.048	.048
2.062	COL3309Z1	COL3309SS	.281	1.531	.500	.312	.062	.375	.048	.048
	COL3311Z1	COL3311SS	.343	1.593	.625	.375	.062	.437	.048	.048
	COL3313Z1	COL3313SS	.406	1.656	.750	.437	.062	.500	.048	.048
	COL3315Z1	COL3315SS	.468	1.718	.750	.500	.062	.562	.048	.048
	COL3317Z1	COL3317SS	.531	1.781	1.000	.562	.062	.625	.048	.048
2.125	COL3409Z1	COL3409SS	.281	1.562	.500	.312	.062	.375	.048	.048
	COL3411Z1	COL3411SS	.343	1.625	.625	.375	.062	.437	.048	.048
	COL3413Z1	COL3413SS	.406	1.688	.750	.437	.062	.500	.048	.048
	COL3415Z1	COL3415SS	.468	1.750	.750	.500	.062	.562	.048	.048
	COL3417Z1	COL3417SS	.531	1.812	1.000	.562	.062	.625	.048	.048
2.187	COL3509Z1	COL3509SS	.281	1.593	.500	.312	.062	.375	.048	.048
	COL3511Z1	COL3511SS	.343	1.656	.625	.375	.062	.437	.048	.048
	COL3513Z1	COL3513SS	.406	1.718	.750	.437	.062	.500	.048	.048
	COL3515Z1	COL3515SS	.468	1.781	.750	.500	.062	.562	.048	.048
	COL3517Z1	COL3517SS	.531	1.844	1.000	.562	.062	.625	.048	.048

Additional clamping diameters and configurations are available.

WIRING AND TUBE CLAMPS – MEDIUM DUTY Closed Type – Fur



COL

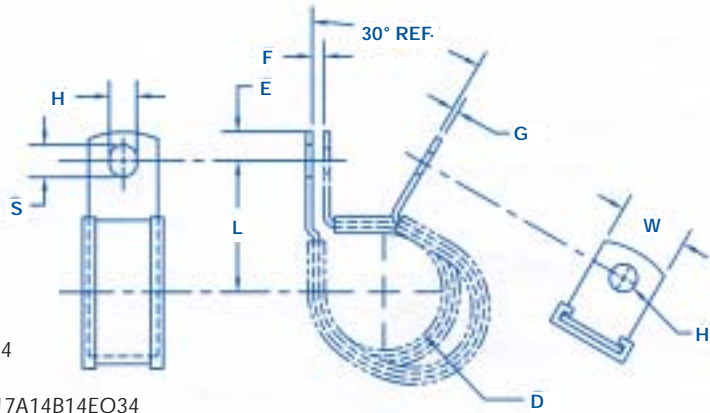

MATERIAL: HD Galv Steel, Chem-Treated G90,
Per ASTM A653/A653M
Type 304 Annealed Stainless Steel,
Per ASTM A240/A666

CUSHION: EPDM per SAE J200/ASTM D2000 BC715A14C12EO34

OPTIONAL CUSHION: Neoprene per AMS3209 SAE J200/ASTM D2000 BC717A14B14EO34
Silicone per AMS3303 SAE J200/ASTMD2000 M2GE506

D Clamping Diameter	Part Number		H Hole Diameter	L Center To Center	W Width	E Hole Center To End	F Gap	S Slot Length	Gage	
	HD Galv Part Number	Stainless Part Number							HD Galv Gage	Stainless Gage
									±.005	±.031
2.250	COL3609Z1	COL3609SS	.281	1.625	.500	.312	.062	.375	.048	.048
	COL3611Z1	COL3611SS	.343	1.687	.625	.375	.062	.437	.048	.048
	COL3613Z1	COL3613SS	.406	1.750	.750	.437	.062	.500	.048	.048
	COL3615Z1	COL3615SS	.468	1.812	.750	.500	.062	.562	.048	.048
	COL3617Z1	COL3617SS	.531	1.875	1.000	.562	.062	.625	.048	.048
2.375	COL3809Z1	COL3809SS	.281	1.687	.500	.312	.062	.375	.048	.048
	COL3811Z1	COL3811SS	.343	1.750	.625	.375	.062	.437	.048	.048
	COL3813Z1	COL3813SS	.406	1.812	.750	.437	.062	.500	.048	.048
	COL3815Z1	COL3815SS	.468	1.875	.750	.500	.062	.562	.048	.048
	COL3817Z1	COL3817SS	.531	1.937	1.000	.562	.062	.625	.048	.048
2.500	COL4009Z1	COL4009SS	.281	1.750	.500	.312	.062	.375	.048	.048
	COL4011Z1	COL4011SS	.343	1.812	.625	.375	.062	.437	.048	.048
	COL4013Z1	COL4013SS	.406	1.875	.750	.437	.062	.500	.048	.048
	COL4015Z1	COL4015SS	.468	1.937	.750	.500	.062	.562	.048	.048
	COL4017Z1	COL4017SS	.531	2.000	1.000	.562	.062	.625	.048	.048
2.625	COL4209Z1	COL4209SS	.281	1.812	.500	.312	.062	.375	.048	.048
	COL4211Z1	COL4211SS	.343	1.875	.625	.375	.062	.437	.048	.048
	COL4213Z1	COL4213SS	.406	1.937	.750	.437	.062	.500	.048	.048
	COL4215Z1	COL4215SS	.468	2.000	.750	.500	.062	.562	.048	.048
	COL4217Z1	COL4217SS	.531	2.062	1.000	.562	.062	.625	.048	.048
2.750	COL4409Z1	COL4409SS	.281	1.875	.500	.312	.062	.375	.048	.048
	COL4411Z1	COL4411SS	.343	1.937	.625	.375	.062	.437	.048	.048
	COL4413Z1	COL4413SS	.406	2.000	.750	.437	.062	.500	.048	.048
	COL4415Z1	COL4415SS	.468	2.062	.750	.500	.062	.562	.048	.048
	COL4417Z1	COL4417SS	.531	2.125	1.000	.562	.062	.625	.048	.048

Additional clamping diameters and configurations are available.

WIRING AND TUBE CLAMPS – MEDIUM DUTY Closed Type – Furnished Open – Extr

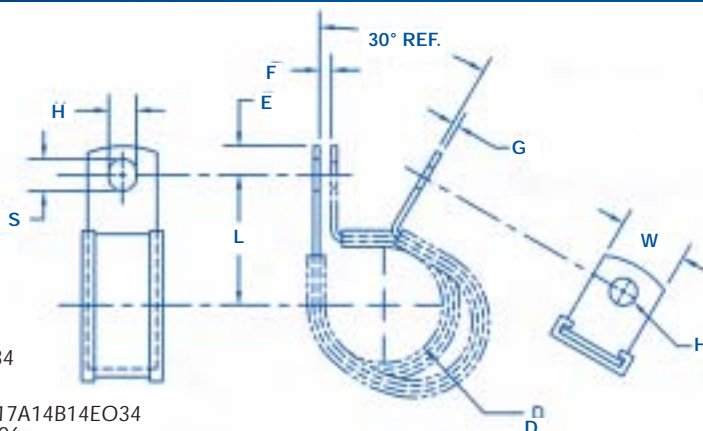

MATERIAL: HD Galv Steel, Chem-Treated G90,
Per ASTM A653/A653M

Type 304 Annealed Stainless Steel,
Per ASTM A240/A666

CUSHION: EPDM per SAE J200/ASTM D2000 BC715A14C12EO34

OPTIONAL CUSHION: Neoprene per AMS3209 SAE J200/ASTM D2000 BC717A14B14EO34
Silicone per AMS3303 SAE J200/ASTMD2000 M2GE506

D Clamping Diameter	Part Number		H	L	W	E	F	S	Gage	
	HD Galv Part Number	Stainless Part Number	Hole Diameter	Center To Center	Width	Hole Center To End	Gap	Slot Length	HD Galv Gage	Stainless Gage
±.031			±.005	±.031	±.010	±.015	±.031	±.020	±.002	±.002
2.875	COL4609Z1	COL4609SS	.281	1.937	.500	.312	.062	.375	.048	.048
	COL4611Z1	COL4611SS	.343	2.000	.625	.375	.062	.437	.048	.048
	COL4613Z1	COL4613SS	.406	2.062	.750	.437	.062	.500	.048	.048
	COL4615Z1	COL4615SS	.468	2.125	.750	.500	.062	.562	.048	.048
	COL4617Z1	COL4617SS	.531	2.188	1.000	.562	.062	.625	.048	.048
3.000	COL4809Z1	COL4809SS	.281	2.000	.500	.312	.062	.375	.048	.048
	COL4811Z1	COL4811SS	.343	2.062	.625	.375	.062	.437	.048	.048
	COL4813Z1	COL4813SS	.406	2.125	.750	.437	.062	.500	.048	.048
	COL4815Z1	COL4815SS	.468	2.187	.750	.500	.062	.562	.048	.048
	COL4817Z1	COL4817SS	.531	2.250	1.000	.562	.062	.625	.048	.048
3.250	COL5209Z1	COL5209SS	.281	2.125	.500	.312	.062	.375	.048	.048
	COL5211Z1	COL5211SS	.343	2.187	.625	.375	.062	.437	.048	.048
	COL5213Z1	COL5213SS	.406	2.250	.750	.437	.062	.500	.048	.048
	COL5215Z1	COL5215SS	.468	2.312	.750	.500	.062	.562	.048	.048
	COL5217Z1	COL5217SS	.531	2.375	1.000	.562	.062	.625	.048	.048
3.500	COL5609Z1	COL5609SS	.281	2.250	.500	.312	.062	.375	.048	.048
	COL5611Z1	COL5611SS	.343	2.312	.625	.375	.062	.437	.048	.048
	COL5613Z1	COL5613SS	.406	2.375	.750	.437	.062	.500	.048	.048
	COL5615Z1	COL5615SS	.468	2.437	.750	.500	.062	.562	.048	.048
	COL5617Z1	COL5617SS	.531	2.500	1.000	.562	.062	.625	.048	.048
3.750	COL6009Z1	COL6009SS	.281	2.375	.500	.312	.062	.375	.048	.048
	COL6011Z1	COL6011SS	.343	2.437	.625	.375	.062	.437	.048	.048
	COL6013Z1	COL6013SS	.406	2.500	.750	.437	.062	.500	.048	.048
	COL6015Z1	COL6015SS	.468	2.562	.750	.500	.062	.562	.048	.048
	COL6017Z1	COL6017SS	.531	2.625	1.000	.562	.062	.625	.048	.048
4.000	COL6409Z1	COL6409SS	.281	2.500	.500	.312	.062	.375	.048	.048
	COL6411Z1	COL6411SS	.343	2.562	.625	.375	.062	.437	.048	.048
	COL6413Z1	COL6413SS	.406	2.625	.750	.437	.062	.500	.048	.048
	COL6415Z1	COL6415SS	.468	2.687	.750	.500	.062	.562	.048	.048
	COL6417Z1	COL6417SS	.531	2.750	1.000	.562	.062	.625	.048	.048

Additional clamping diameters and configurations are available.

Note: Joggle in lower leg is not available on clamping diameters larger than 2.75 inches. Clamp will have a straight leg.